

SADE SP260

Weight Sorter/Checkweigher for tablets, capsules, soft-gels, and mini-tabs

When precision and accuracy count

The SADE SP260 will accurately and quickly sort your batches of tablets and capsules by weight and into accept and reject categories. It is a floor standing unit with two weighing channels each fed by a 60 litre bulk hopper. It can operate over a 24 hour period with minimal involvement allowing your operators to get on with other tasks. Dismantling for cleaning is rapid and it's easy to set up for the next product

PRODUCTION — Recover valuable product

Enables you to reclaim your weight acceptable product from rejected batches – reducing wastage and cost.

Savings can be made recovering valuable product made during press run-in and run-out stages.

R&D — Ensures weight uniformity

100% weight checking and statistical analysis of clinical trial or development batches. Ideal tool for checking over encapsulation.

KEY FEATURES

- Sorts tablets, capsules, soft gels and mini-tabs
- Handles all shapes and sizes
- No change parts required
- High accuracy ± 1 mg
- Simple to operate
- Quick and easy clean down
- 24 hour operation
- Minimal operator involvement
- Data integrity – full 21CFR Part 11 and Annex 11 compliance
- Full audit trail
- Domain authentication available
- OPC UA data protocol available

SADE SP260

Weight Sorter/Checkweigher for tablets, capsules, soft-gels, and mini-tabs

KEY OPERATIONAL BENEFITS

Our SADE SP units are delivering precision weight sorting for the world's leading pharmaceutical companies around the globe.

Maximise speed and accuracy, minimise cost

- Consistent and precision weight sorting with an accuracy of +/- 1 mg
- Versatile unit sorts tablets and capsules of different shapes and sizes
- No need for costly format parts and time consuming change over's
- Fast effective clean down – boosts operational efficiency
- Quick and easy batch set up via improved user interface
- Minimal operator involvement required – saving time and funds
- Proven design and quality materials for ease of cleaning

Informed decision making and action taking

- New touch screen provides real time display of statistical data
- Prints detailed reports directly via USB local or network printer
- Data can be transferred to your PC
 - enhanced reports automatically saved as secure pdf files

TECHNICAL DETAILS

Mounting	Floor standing
Weighing Channels	2
Sorting Rate	Up to 9000 items per/hr Varies per product and weighing environment
24 hour operation	Up to 210,000 per 24 hour period
Bulk Hopper Capacity	2 x 60 Litres
Weight Range	20mg - 2g
Product Size	Tablets: Up to 24mm length, 20 mm wide Capsules: 00, 0, 1, 1e1, 2, 2e1, 3, 4, 4e1, 5 (Size 000, 00e1 available on request Contact CI Precision for details)
Balance Readability	0.1 mg
Reproducibility	+/- 1mg
Zero System	Automatic
Contact Parts	316/316L electro-polished stainless steel and PEEK polyetheretherketone FDA 21 CFR 177.2415
Dimensions(mm)	944D x 1098W x 1461H
Voltage&Frequency	115/230 VAC 50/60 Hz
Air Supply	Clean dry air 3-5 bar or 43-73PSI

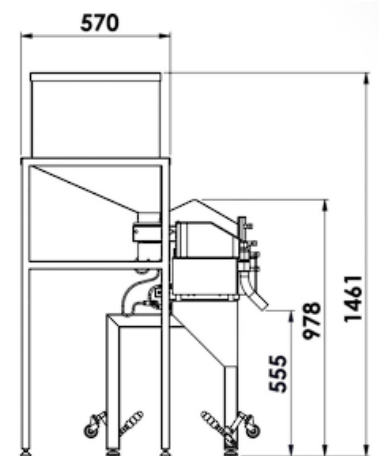
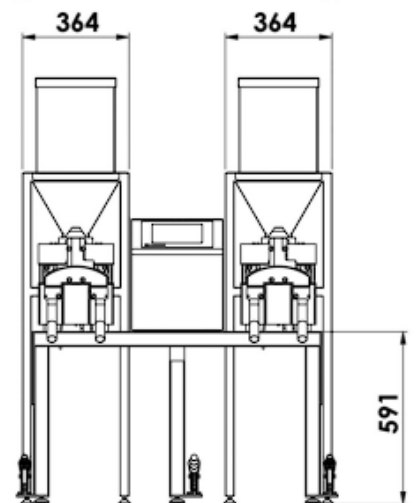

Brunel Road, Churchfields
Salisbury, Wiltshire
SP2 7PX United Kingdom

T +44 (0)1722 424100
E sales@ciprecision.com

www.ciprecision.com